

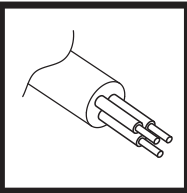

Temperature control, 35mm DIN rail mounting, cable connection

Electrical connection	Set point adjustment	Mounting	Action	Contact Rating	T° ranges min and max adjustment limits	Types
Cable	- 10mm shaft - Screwdriver on dial - Fixed setting	Rear 35mm DIN Rail	Control	SPDT 16(4)A, 400VAC 25(4)A, 250VAC	-50 to + 50°C	KAB-4
						

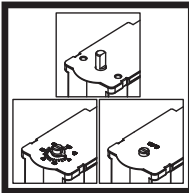
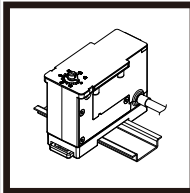
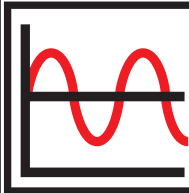
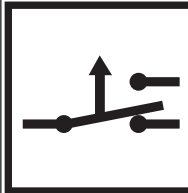
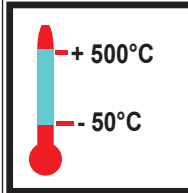
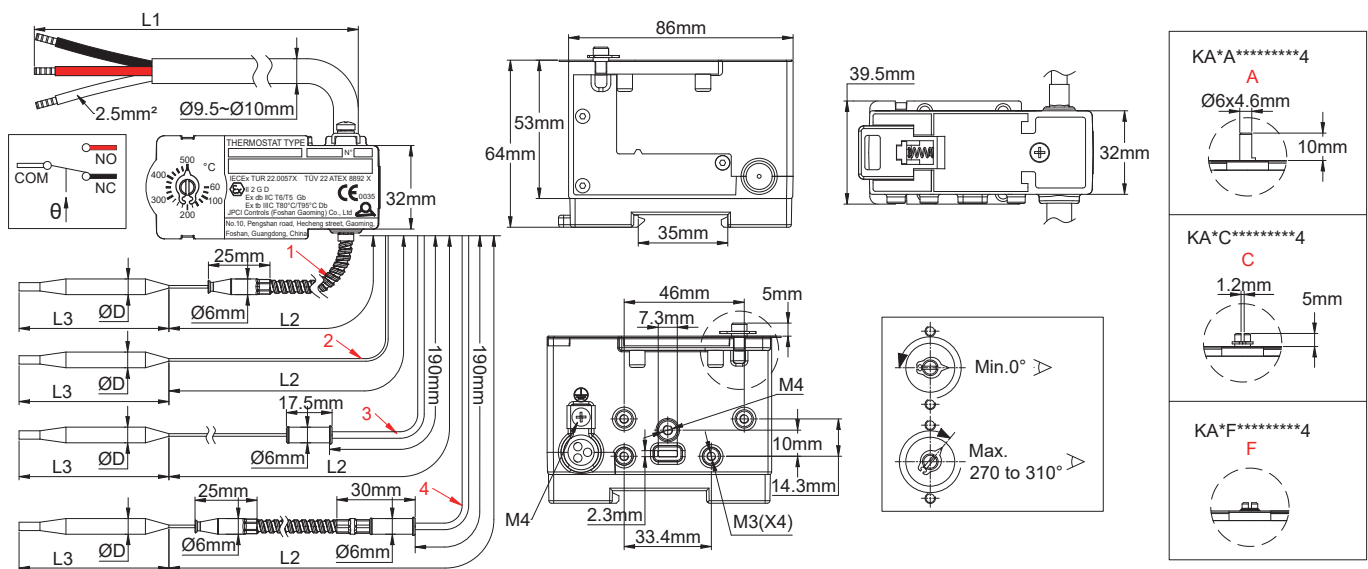
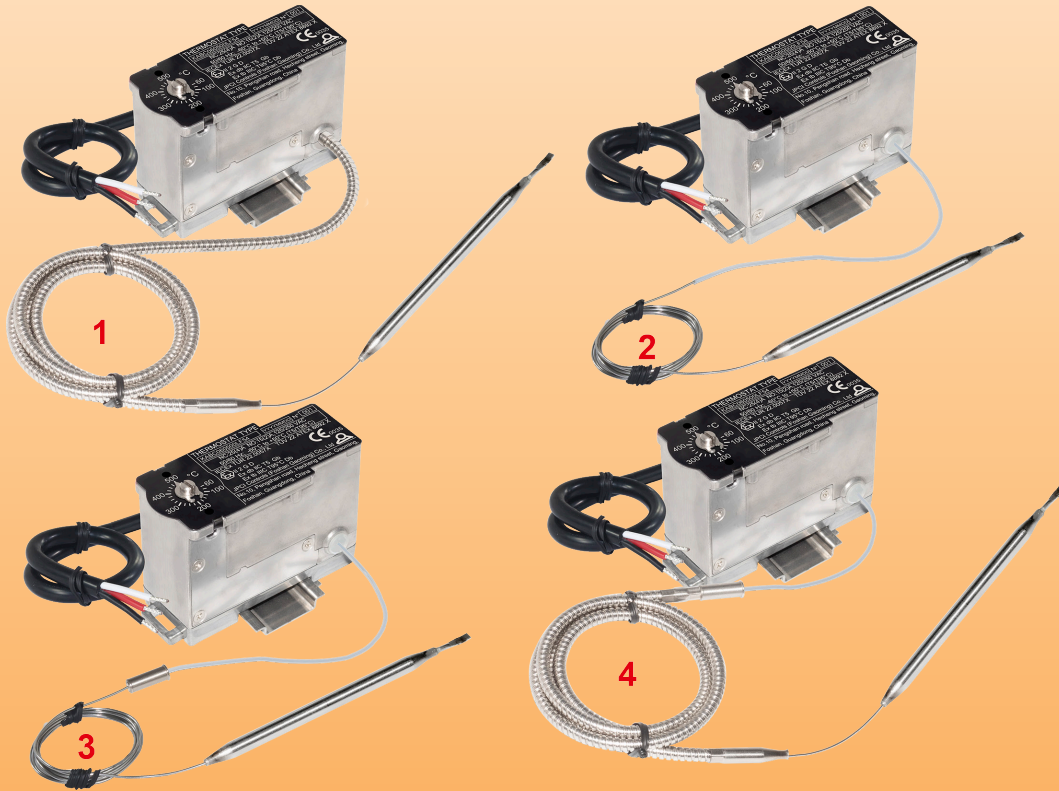

Because of permanent improvement of our products, drawings, descriptions, features used on these data sheets are for guidance only and can be modified without prior advice

Types of capillary outputs

- 1: Capillary protected by a flexible stainless steel metal sheath over its entire length, right out of the thermostat body. The 6mm dia. end of the stainless-steel protective sheath is rounded to avoid shearing of the capillary, and the 6mm diameter allows the mounting of accessories such as flange or thermowell (Patented). **This is the capillary protection recommended for thermostats with cable connection.**
- 2: Bare 1mm capillary without any protection.
- 3: Capillary comprising a 6mm diameter brazed fitting allowing an EX “e” box outlet via a cable gland with a 6mm passage. The part of the capillary located inside the EX “e” box is protected against the risks of electrical contact by a PTFE sheath, and the external part is bare.
- 4: Capillary comprising a 6mm diameter brazed fitting allowing an EX “e” box outlet via a cable gland with a 6mm passage. The part of the capillary located inside the EX “e” housing is protected against the risks of electrical contact by a PTFE sheath, and the external part by a flexible metal sheath in stainless steel. The 6mm dia. end of the stainless- steel protective sheath is rounded to avoid shearing of the capillary, and the 6mm diameter allows the mounting of accessories such as flange or thermowell (Patented). **This is the capillary protection recommended for thermostats with EX “e” box.**

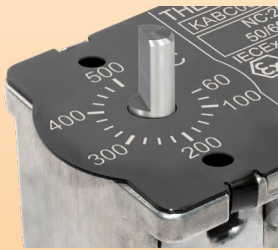

A: Shaft dia. 6mm, length 10mm, for use with printed knobs and bezels, or small plastic arrow knob (available as accessories below);

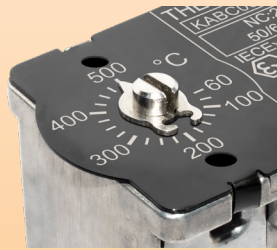

C: Screw driver type, with arrow and printed aluminum dial, for use in PPS Ex-e enclosure of JPCI or other suppliers for heat tracing;



F: Fixed and sealed temperature adjustment

General rules for installation:

Important note: These thermostats are intended to monitor or control temperatures in gas or dust hazardous areas.

They can be installed in a variety of enclosures, and they can be explosion-proof enclosures, increased safety models, flameproof models, etc., or non explosion-proof enclosures, as long as they comply with the requirements of IP54 and above, and do not damage the integrity of “db” and “tb” based on the requirements of IEC 60079-0. However, we recommend that the electrical connection at the end of the cable be made in an EX “e” box.

For gas hazardous areas, this equipment is approved as “Ex db” and is suitable for use in zone 1 and zone 2, gas group IIC (Hydrogen/Acetylene, the highest protection group), with a temperature classification T5/ T6;

For dust hazardous areas, this equipment is approved as “Ex tb”, suitable for use in zone 21 and zone 22, the dust group is IIIC (electric conductive dust, the highest protection group).

The applicable ambient temperature of the equipment is:

NC: 16(4)A NO: 10(2)A, 125/250/400 VAC; 50/60 Hz; -60°C to +50°C (T6/T80°C)

NC: 16(4)A NO: 10(2)A, 125/250/400 VAC; 50/60 Hz; -60°C to +80°C (T5/T95°C)

NC: 25(4)A NO: 15(2)A, 125/250 VAC; 50/60 Hz; -60°C to +50°C (T5/T95°C)

The outlet of the capillary from this box must be carried out by a cable gland with a gasket adapted to the 6mm diameter of the capillary connection fitting and providing the degree of protection required by the standard.

The models with screw driver adjustment and front mounting allow incorporation inside most existing junction boxes in having inside a free height of 65mm minimum above the DIN rail.

With an adjustment per 10mm shaft and printed knob, this minimum height is about 75mm. We recommend checking this height by requesting plans for the devices with the knob of your choice.

Approvals: These thermostats are certified:

ATEX: TÜV 22 ATEX 8892 X; IECEx: IECEx TUR 22. 0057 X. CCC: 2025012304765427

Housing: Aluminum, 86 × 40 × 64mm (Dimensions without shaft and knob)

Bulb and capillary: Stainless steel. Standard capillary length 1500mm. (Other lengths available with M.O.Q) Capillary minimum bending radius 5mm.

Temperature sensing element: Oil or liquid metalloids filled bulb and capillary.

Electrical connection: Silicone insulated wires H05S-K, 2.5mm², T180°C, 450V, standard length 200mm. Wire ends with crimped terminals. Other lengths on request.

Ground terminals: One M4 grounding terminals with saddle is located on the wire exit side.

Mounting: Rear side, on symmetrical 35mm DIN rail

Contacts: SPDT, snap action contact. Electrical life 100,000 cycles.

Electrical rating: Suitable for power control, remote control of relay coils or PLCs circuits.

Voltage	Maximum rating (A) between:	
	Common (white) and normally closed (black)	Common (white) and normally open (red)
400V AC	16 (4)	10(2)
250V AC	25 (4)	15(2)
125V AC	25 (4)	15(2)



Explosion proof bulb and capillary thermostats for incorporation



These devices use silver contacts or silver alloy contacts. Due to the possible oxidation of the contacts in time, we do not recommend the use of AC or DC low-voltage circuits (24V or less) if the switched intensity is less than 100mA, or the switched power less than 800mW. Contact us for those applications that require gold-plated contacts. The electrical ratings given are normalized resistive circuit values.

Options:

- Capillary sleeved with 6mm diameter stainless steel flexible tube
 - Capillary with fitting for 6mm cable gland gasket, with or without capillary sleeving in stainless steel
- Mechanical life: > 500,000 cycles

Classification:

Gas: $\text{Ex II 2G Ex db IIC T5/T6 Gb}$
 Dust: $\text{Ex II 2D Ex tb IIIC T95°C/T80°C Db}$





Main references with 1000mm cable length (L1) and capillary output type 4**

References with screw driver with arrow adjustment shaft	References with 10mm adjustment shaft	Temperature range	Capillary length (L2, mm)	Bulb diameter (D, mm)	Bulb length (L3, mm)	Differential (°C)	Max temperature on bulb
KABC-35035L1A4	KABA-35035L1A4	-35~35°C (-31~95°F)	1500	6	100	3.5±1	60°C (140°F)
KABC-10040L2A4	KABA-10040L2A4	-10~40°C (-14~104°F)	1500	6	130	2.5±1	70°C (158°F)
KABC-20050L3A4	KABA-20050L3A4	-20~50°C (-4~122°F) *	1500	6	90	3.5±1	80°C (176°F)
KABC004040L4A4	KABA004040L4A4	4~40°C (39.2~104°F)	1500	6	140	2±1	70°C (158°F)
KABC004040L5A4	KABA004040L5A4	4~40°C (39.2~104°F)	1500	8	80	2±1	70°C (158°F)
KABC000060L6A4	KABA000060L6A4	0~60°C (32~140°F)	1500	6	115	3±1	90°C (194°F)
KABC030090L7A4	KABA030090L7A4	30~90°C (86~194°F)	1500	6	110	3±1	120°C (248°F)
KABC000100L8A4	KABA000100L8A4	0~100°C (32~212°F)	1500	6	80	5±1.5	130°C (266°F)
KABC030110L9A4	KABA030110L9A4	30~110°C (86~230°F)	1500	4	120	7.5±2.5	230°C (446°F)
KABC000200LAA4	KABA000200LAA4	0~200°C (32~392°F)	1500	4	100	10±3	230°C (446°F)
KABC050200LBA4	KABA050200LBA4	50~200°C (122~392°F)	1500	4	120	7.5±2.5	230°C (446°F)
KABC000300LCA4	KABA000300LCA4	0~300°C (32~570°F)	1500	4	70	15±5	330°C (626°F)
KABC050300LDA4	KABA050300LDA4	50~300°C (122~572°F)	1500	4	80	12±4	330°C (626°F)
KABC050400LEA4	KABA050400LEA4	50~400°C (122~752°F)	1500	4	50	18±6	430°C (806°F)
KABC060500LFA4	KABA060500LFA4	60~500°C (140~932°F)	1500	4	120	20±6°C	550°C (1000°F)

* The filling liquid of these thermostatic assemblies has a freezing temperature of about -50°C (-58°F). However it is important to protect the bulb and /or the capillary against the risk of freezing if a temperature below -35°C (-31°F) can be reached in operation. Acceptable storage temperature: -50°C(-58°F).

** For a longer wire, replace the 13th character (A) by B for 2m, C for 3m, D for 4m a.s.o. For a type 1 capillary outlet: Replace the 11th character (L) with G; For a type 2 capillary outlet: Replace the 11th character (L) with C; For a type 3 capillary outlet: Replace the 11th character (L) with P;

Accessories (to be ordered separately)

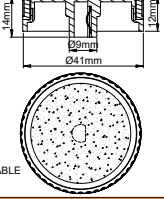
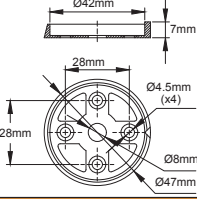
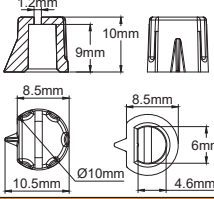
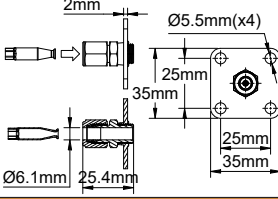
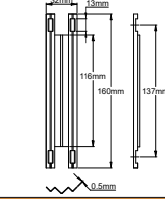
Dia 40mm printed knob*	Bezel for 40mm knob*	Miniature arrow knob*	Pipe liner crossing flange	Bulb fixing profile on pipes
				
				
This knob is printed according to the temperature range of the thermostat. Available in °C or °F. It is used when the thermostat is mounted from the front, with the adjustment shaft passing through the mounting board.	Allows the positioning of the temperature mark on the knob.	To be mounted on the thermostat when it is fixed from the rear in an enclosure. Its size is greater than the arrow used with screwdriver adjustment.	This flange makes it possible to pass through the protective metal sheath located around the thermal insulation of the pipes, without risk of breaking the capillary. It is tightened by a bicone on the 6mm dia. end of the stainless-steel sheathing of the capillary	This profile makes it possible to securely fix with two clamps a thermostat bulb in contact with the wall of a pipe
66MZ	66EN1	66MQ	66KAMB35356	6YTPF160032

* Many other knobs and bezels are described in our catalogue N°1

This cable output cannot be used with cable length more than 2m for ratings between 16A and 25A.

Because of permanent improvement of our products, drawings, descriptions, features used on these data sheets are for guidance only and can be modified without prior advice